

PEDESTRIAN SIMULATION CONSIDERING STOCHASTIC ROUTE CHOICE AND MULTIDIRECTIONAL FLOW

Miho Asano

PhD student, Institute of Industrial Science, University of Tokyo
Cw-504, 4-6-1 Komaba, Meguro-ku, Tokyo, 153-8505, JAPAN
Tel: +81-3-5452-6419, Fax: +81-3-5452-6420, E-mail: asano@iis.u-tokyo.ac.jp

Masao Kuwahara

Professor, Institute of Industrial Science, University of Tokyo
Cw-504, 4-6-1 Komaba, Meguro-ku, Tokyo, 153-8505, JAPAN
Tel: +81-3-5452-6419, Fax: +81-3-5452-6420, E-mail: kuwahara@iis.u-tokyo.ac.jp

Agachai Sumalee

Senior research fellow, Institute for Transport Studies, University of Leeds
Leeds LS2 9JT UK
Tel: +44-113-3435345, Fax: +44-113-3435334, E-mail: A.Sumalee@its.leeds.ac.uk

Shinji Tanaka

Research associate, Institute of Industrial Science, University of Tokyo
Cw-504, 4-6-1 Komaba, Meguro-ku, Tokyo, 153-8505, JAPAN
Tel: +81-3-5452-6419, Fax: +81-3-5452-6420, E-mail: stanaka@iis.u-tokyo.ac.jp

Edward Chung

Adjunct professor, Institute of Industrial Science, University of Tokyo
Cw-504, 4-6-1 Komaba, Meguro-ku, Tokyo, 153-8505, JAPAN
Tel: +81-3-5452-6419, Fax: +81-3-5452-6420, E-mail: edward@iis.u-tokyo.ac.jp

ABSTRACT

This paper proposes a framework of a dynamic pedestrian model integrated with a strategic route choice model and multi-directional flow propagation. Despite a vast number of proposed pedestrian models especially in the last decade, very few of these considered both pedestrian's route choice behavior and physical movement in a single integrated framework. In an open space, even after the discretization of the space, a massive number of possible paths for pedestrians can possibly be defined. However, psychologically we obviously do not consider all these paths as distinct options. Thus, pedestrians in this model are assumed to choose a series of consecutive sub-areas to traverse along at first instance. Then, the model allocates the actual flows on each detailed path based up on an assumption of dynamic user optimum (DUO). Combining these two stages of flow allocation, the model thus assumes a hierarchical decision of pedestrian's route choice. In this paper, a modified cell-transmission model (CTM) is adopted to represent the physical phenomena of congestion and dynamical propagation of pedestrian flows. A key difference to the original CTM is that the pedestrian flow is multi-directional by its nature. Thus, the paper proposes an approach to extend the analysis in the original CTM to consider the multi-directional movement. The paper also illustrates the plausibility of the proposed modified CTM by testing with a test case.

1. INTRODUCTION

Recently, the importance of walking as a part of a trip has regained a significant level of interest from transport planning society. For instance, in the UK government transport white paper, a key target on improving the condition of pedestrian infrastructure and encouraging walking has been included (DfT, 2000). This is also supported by the realization of the important role of walking in a successful sustainable transport development. In addition, walking has been a major mode of transport in several major cities with a very high density of population and public transport services (e.g. in Tokyo, London, or Hong Kong).

Despite its growing importance, there has been a rather lack of development of an appropriate modeling tools for help evaluating or planning the improvement of pedestrian infrastructure. Two main research issues for pedestrian model development are (i) a plausible framework for pedestrian route choice or movement behavior and (ii) a realistic model for representing a physical congestion and interaction of pedestrian flows. These issues are significantly challenging as compared to some previous researches carried out for the automobile case.

The space for physical movement in the case of pedestrian model can be considered as a rather continuum one compared to the case of discrete representation of a road network. The concept of preferred routes or trajectories for pedestrians in this case is thus rather different from those normally considered in the road network. In a continuum space, even after applying a form of discretization scheme, a potentially massive number of trajectories or paths for pedestrian movement can be defined. Hoogendoorn and Bovy (2004) proposed a continuum-space pedestrian model which allows the pedestrian to choose activity location, schedule and route choice (which is defined as a trajectory in a continuum space). However, psychologically these trajectories or paths are obviously not considered as distinct options or chosen prior to the actual movement. In this paper, we propose a hierarchical route choice (or trajectory) model in which at the upper level the pedestrian is assumed to consider a route choice as a choice of different series of areas he or she has to traverse along. After this initial stage of decision, once the pedestrian starts his/her journey the actual movement or route within each area will be determined subsequently by a principle of Dynamic User Optimum (Kuwahara and Akamatsu, 1997). Similar to the position made in (2), the actual movement of pedestrian in this case is defined into two stages, i.e. tactical (area choice) and operational (actual trajectory within each area) stages. Antonini *et al* (2006) using an empirical data and discrete choice model illustrated an evidence that people, if possible, are moving toward their pre-determined trajectory which can be defined at a higher level of decision as contrast to the movement actually made at the operational level.

For the congestion model or flow-propagation model, the nature of pedestrian flow and the flexibility of the pedestrian movement (i.e. no directional constraint of flow), unlike traffic, requires a more complex representation of the interaction in order to reproduce a realistic delay-density relationship. Several researchers have attempted to employ a micro-representation of pedestrian behavior, similar to micro-simulation model for traffic (Helbing and Molnar, 1995, Blue and Adler, 2001). The other philosophy has been on attempting to consider pedestrian flows in a more aggregated fashion following the development in the traffic area in which a form of speed-flow relationship has been investigated. Hughes (2002) developed a theoretical framework for bi-directional pedestrian speed-flow based on the fluid mechanics. Lam *et al* (2003) proposed a speed-flow formulation for bi-directional traffic which was validated by the data from a study with different Hong Kong walkways. It is still arguable on which modeling paradigm is more appropriate.

In this paper, we propose an aggregated dynamic flow model for representing congestion phenomena. The paper applies the original concept of Cell Transmission Model (CTM) as proposed by Daganzo (1994 and 1995). CTM is a macroscopic flow model which is equivalent to the kinematic wave theory for the vehicular traffic case. In a general case, pedestrian flows may have a higher order of interaction (i.e. for a single unit of space there could be more than one direction of flows interacting inside that space), especially in a crowded space (e.g. subway station or shopping centre). The original CTM does not handle the case with multi-direction flow/density. The paper, thus, extends the formulation to allow for the multi-direction flow and density treatment.

This paper is structured into five further sections. The next section gives an overview of the integrated route choice and dynamic pedestrian modeling framework proposed in this paper. Then, the third section explains the concept of route choice model developed in this paper including the discussion on the tactical route choice model. The fourth section then moves on to the discussion of the dynamic flow-propagation model in which an extension of the original CTM to the case of multi-directional flow is explained. The fifth section presents some tests with the route choice and flow-propagation model. The final section concludes the paper and discusses future research.

2. FRAMEWORK OF AN INTEGRATED DYNAMIC PEDESTRIAN ROUTE CHOICE AND FLOW MODEL

An overall framework of an integrated dynamic pedestrian route choice and flow simulation model proposed in this paper is shown in Figure 1. Similar to a standard vehicle simulation model, this model consists of 3 components: route generation model, route choice model and flow propagation model. In this paper, the terms *route* and *path* have different meanings as shown in Figure 2. A path refers to a trajectory of pedestrians. A route is, on the other hand, is a collection of different paths sharing the same sequence of related areas. Although there potentially exist an infinite number of paths, pedestrians only perceive a limited set of routes defined by a series of consecutive sub-areas in the area considered.

A route generation model defines a choice set of possible routes for each group of pedestrians. The model will collate similar paths into a route based on the topology of the area. The pedestrian will then decide which route to take based upon the generalized travel cost on each route. The route choice model can be based on either deterministic (i.e. Wardrop's equilibrium) or stochastic user equilibrium (SUE) principles.

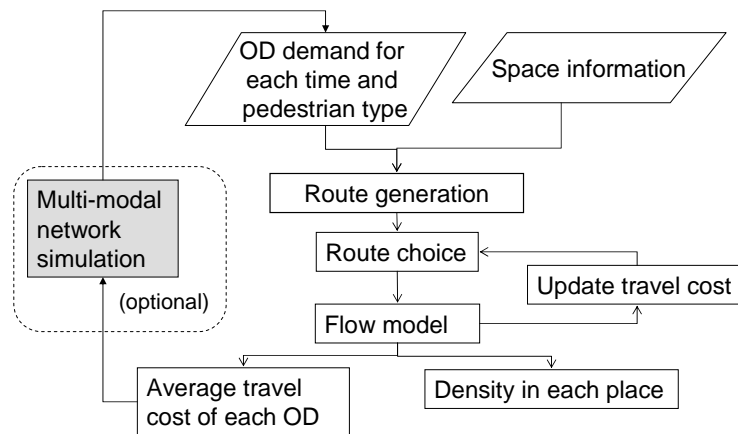

Figure 1: Framework of pedestrian simulation

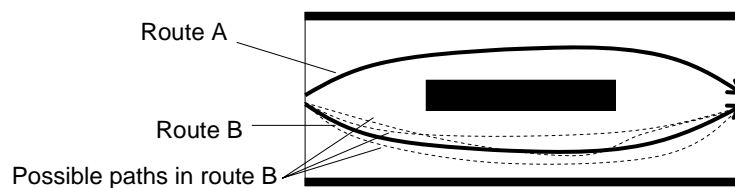

Figure 2: Definition of route and path

For a chosen route, the demand associated with that route is then loaded into the flow propagation model. The flow propagation model performs the dynamic flow propagation and calculates the delay occurring at each time and location. The flow propagation model as discussed earlier is based on the cell-transmission model (CTM) which divides a continuum space into a number of cells, and pedestrian can move in and out from each cell with the delay based on speed-density relationship considering interaction of multi-directional flows.

3. ROUTE CHOICE MODEL

3-1 Network structure for pedestrian

There are two types of space representation for the pedestrian route choice model: (i) link-based model and (ii) potential model (see Figure 3 for graphical examples). The link-based model represents the topology of the area by a set of links and nodes in which an area can be defined by a node and a possible path can be defined as a link (see for example, Gloor, *et al*, 2004). With this representation, a number of existing theories and results from the vehicular network analysis field can be directly applied to the pedestrian model. However, due to a rather open space and free movement of pedestrians defining appropriate relationship between walking space and links in the network can be problematic. The second form of space representation is the so called “potential model” (e.g. Hoogendoorn and Bovy, 2004). In this representation, an area is simply defined as a continuum plane in which pedestrian flows interacts at each vector location inducing a form of delay. The pedestrian in this model will then find a shortest path from any possible continuous trajectories. As shown in Figure 3 below, a contour of cost (or delay) at each continuous location on this plane can be defined in which the shortest path from one point to another is the trajectory with the steepest descent direction on this contour line. As mentioned, in this model pedestrians are assumed to choose a path from the infinite set of possible trajectories which contradicts to our preliminary observation about the perception of possible “route” in the space.

Although the number of possible routes in the continuum space is infinite, pedestrians in the actual situation are likely to perceive only a certain finite numbers of possible trajectories. For instance, from the topology of the area in Figure 3, one can simply define three main possible routes from the origin to destination in the figure not the infinite number of routes as defined in the potential model. In this paper, we define the model called “Cross-section model” in which it introduce a number of intercept line or cross-section line between obstacles. Each of the area which are defined as a unit by a number of cross-section lines (without any other cross-section line in the middle of the area) is defined as a sub-area in this model. In other words, the cross-section lines divide the whole walking space into a number of unique continuous walking sub areas which are often surrounded by obstacles (as shown in Figure 3). The pedestrians are then assumed to perceive a distinct alternative trajectory of journey (at the tactical level) by a different series of consecutive cross-section lines (or sub-areas). Route is represented as combination of these cross sections in this paper.

For generating sub-areas or cross sections in a general case, general rules or requirements must be defined. Two main requirements for a valid cross-section and sub-area include (i) two different cross sections must not cross each other, and (ii) sub-area consists of only walkable space defined by a finite set of cross-sections. Using some computational algorithms, cross-sections and sub-areas can be automatically or manually defined from a topology of an area. Figure 4 shows an example the resulting cross-sections and sub-areas for an open urban space.

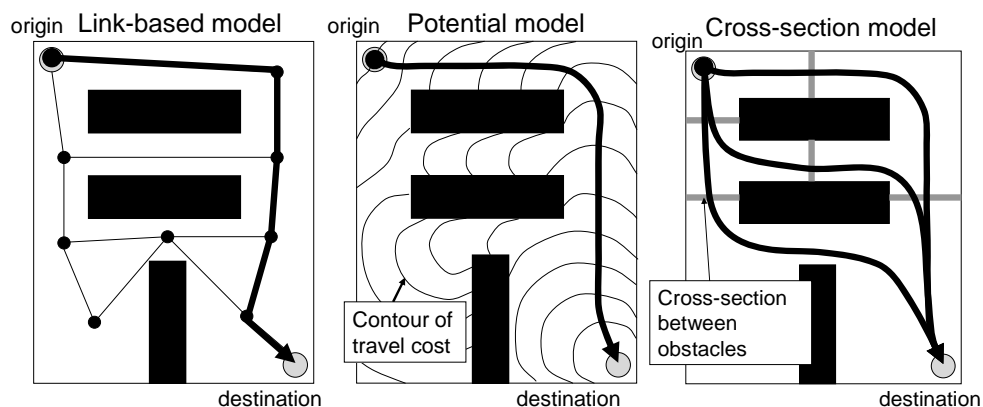

Figure 3: Network structure for route choice of pedestrian

3-3 Path choice

Given that a pedestrian will traverse from cross section i to j (defined by the tactical route choice), the actual trajectory or the operational level of path choice will depend principally on the concept of dynamic user optimum (DUO) in which the pedestrian will traverse along the shortest path considering the path cost at departure time t from the cross section i . The sub-areas are discretized into a number of square cell with the size of 2 - 3m in length as shown in Figure 6. Adjacent cells are connected to each other by tangential surfaces and travel time between one cell to another is defined by the flow propagation model. Pedestrian flows will move dynamically from one cell to any other adjacent cells to traverse along this surface in which the delay in each cell will depend upon the density of multi-direction flows which will be explained next.

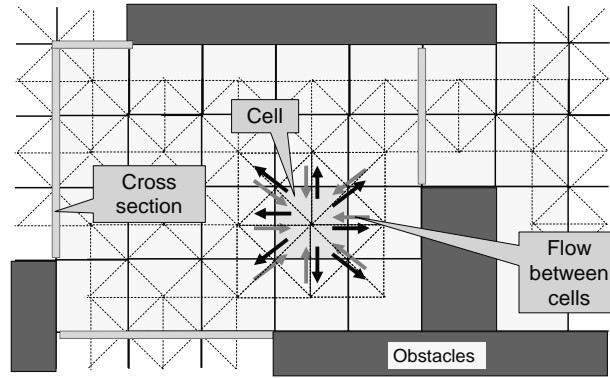

Figure 6: Cell-based network

4. FLOW PROPAGATION MODEL

As discussed in the previous section pedestrians with a given route are loaded to the network and a flow propagation model is applied for representing the congestion phenomena. Both microscopic and macroscopic flow propagation model could be applied in this framework and recently we are analysing from both points of view by using experimental data and observed data. In this paper, we introduce macroscopic model based on cell transmission model.

4-1 Macroscopic approach – Cell Transmission Model

The space in the sub-area is discretized into a number of cells in which a macroscopic flow-density curve is applied to each cell represent the dynamical movement of pedestrians.

The concept of the cell transmission model (CTM) as proposed by Daganzo (1994 and 1995) is utilized in this paper to define a plausible CTM for pedestrian flows. In CTM, the number of vehicles, $y_i(t+\Delta t)$, moving from cell $i - 1$ to i at time $t+\Delta t$ can be calculated considering the possible number of vehicles which can go out from cell $i - 1$, $P_{i-1}(t)$, and the possible number of vehicles which can enter cell i , $S_i(t)$. $P_{i-1}(t)$ and $S_i(t)$ are obtained as follows under flow density curve given as in Figure 7.

$$P_{i-1}(t) = \min\{n_{i-1}(t), Q_{i-1}(t)\} \quad (1)$$

$$S_i(t) = \min\left\{Q_i(t), \frac{w}{v_f}(N_i(t) - n_i(t))\right\} \quad (2)$$

where $n_i(t)$ is the number of vehicles in cell i at time t . $y_i(t)$ is calculated by taking the minimum of these two values.

$$y_i(t) = \min\{P_{i-1}(t), S_i(t)\} \quad (3)$$

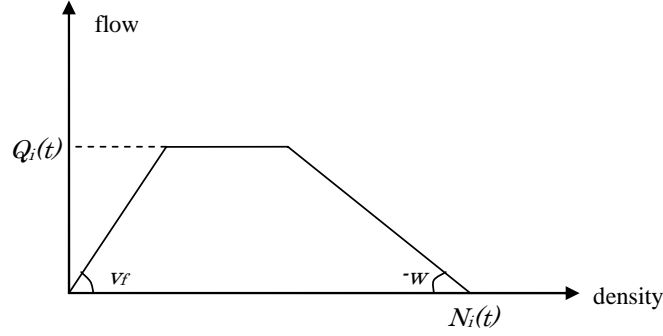

Figure 7: flow-density relationship used for CTM

The original CTM has a restriction on the setting of the size of a cell, L , and the simulation time step, Δt , to guarantee its equivalence to the kinematic wave theory which can be defined as:

$$v_f \cdot \Delta t = L \quad (4)$$

There are three problems in applying this original CTM to the pedestrian flow model. The first is that the walking distance of the diagonal flow is longer than that of the horizontal and vertical flow. This property does not satisfy the requirement in equation (4) to guarantee its consistency with the kinematic wave theory. The second is the effect of multi-directional flows in one cell. In the original CTM, the model is defined for the case with uni-directional flows, especially for the delay calculation and dynamic flow propagation. However, in the case of pedestrian model, there are eight possible directions of flow movements from one cell to the other adjacent cells. Different composition of flows from different direction may result in a rather different level of delay in that cell. In addition, the level of delays experienced by the pedestrians in different directions even located within the same cell may also be different (similar to the case of asymmetric delay function in the case of traffic network). The last issue is related to merging and diverging behaviors of pedestriants which can take place at any cell. The next section discusses some modifications to the original CTM to overcome these issues.

4-2 Modification of CTM

(i) Simulation time step

Assume that there are flows of different direction j in a cell. If v_j is equivalent for all directional flows, the simulation time step, Δt_j must satisfy the following condition:

$$\Delta t_j = \frac{L_j}{v_f} \quad \text{where} \quad L_j = \begin{cases} L & \text{if } j \text{ is horizontal / vertical flow} \\ \sqrt{2}L & \text{if } j \text{ is diagonal flow} \end{cases} \quad (5)$$

To overcome this problem, we set the simulation time interval Δs as smaller than Δt_j , such that

$$\Delta t_j = m_j \Delta s \quad m_j : \text{integer} \quad (6)$$

The simulation model then calculates the flow propagation for each direction j with interval of Δt_j .

(ii) Effect of multi-directional flow

The CTM uses a speed-density curve in each cell to decide the actual amount of flow moving from one cell to another. However, the speed of pedestrian in the multi-directional flow case will decrease due to the conflict between pedestrian with different speeds and directions. The speed of pedestrians depends not only on the number of pedestrians in the cell, but also the desired direction and speeds of the other pedestrians. In order to calculate the speed of the pedestrian at a certain state of the cell, the concept of converted density is adopted in which a conversion function will be applied to the mixture of multi-direction flows to define an equivalent density for that cell under the uni-directional flow case.

The converting function is a function of the densities of pedestrians in different directions in the cell. Depending of the condition of the case considered, different converting functions can be defined. For example, under a highly congested condition, Algadhi and Mahmassani (1990) proposed a function of the speed-flow relationship for the orthogonal crossing situation based on empirical data. On the other hand, in the free flow or very mild congested condition, Naka (1978) concluded that the effect of crossing flows on the speed reduction is not significant. Generally, the converting function $F(n_\alpha, \beta)$ for converting the number of pedestrians n_α in direction α to an equivalent density in the direction β should be a monotone decreasing function of n_α in any cases.

(iii) Merging and diverging

The original CTM considers the merging and diverging behaviors separately at intersections cells. However, in the pedestrian model merging and diverging can take place at any cell since pedestrians can move to any direction. Let consider the flow from cell i to cell j . Cell i has adjacent cells r ($\in \Omega$: set of adjacent cells) and cell j has adjacent cells s ($\in \Phi$: set of adjacent cells).

In the case of multi-directional flow, we assume that total outflow from cell i , i.e. $\sum_r P_{ir}(t + \Delta t_{ir})$, is distributed proportionally to all possible outflows toward all directions, $P_{ir}(t + \Delta t_{ir})$. Then from equation (1), the possible outflow from i to j can be written as follows using the density converting function:

$$P_{ij}(t + \Delta t_{ij}) = \min\left\{F(n_{ij}(t), j), \frac{F(n_{ij}(t), j)}{\sum_r F(n_{ir}(t), j)} Q_i(t)\right\} \quad (7)$$

where $F(n_\alpha, \beta)$ denotes the converted density. For simplicity, we will refer to $F(n_{ij}(t), j)$ as $n_{ij}(t)$ for the rest of the paper. The possible number of pedestrians who can enter cell j in total from all adjacent cells s can be defined as:

$$\sum_s S_{sj}(t + \Delta t_{sj}) = \min\left\{Q_j(t), \frac{w}{v_f} (N_{jam}(t) - \sum_s n_{sj}(t))\right\} \quad (8)$$

The possible inflow from each direction is given based on a certain merging ratio. We assume that the merging ratio $R_{ij}(t + \Delta t_{ij})$ is defined by the proportion of demand from each direction to cell j .

$$R_{ij}(t + \Delta t_{ij}) = \frac{\min(P_{ij}(t + \Delta t_{ij}), S_{ij}(t + \Delta t_{ij}))}{\sum_s \min(P_{ir}(t + \Delta t_{ir}), S_{sj}(t + \Delta t_{sj}))} \quad (9)$$

If the total possible outflow from all of the adjacent cells s to cell j is lower than the possible inflow from all s to j , then all of the flows can enter cell j . Otherwise, the amount of flow to enter from each cell is distributed by $R_{ij}(t + \Delta t_{ij})$. Therefore, the actual number of pedestrians moving from cell i to j can be defined as:

$$y_{ij}(t + \Delta t_{ij}) = \begin{cases} P_{ij}(t + \Delta t_{ij}) & \text{if } \sum_s P_{sj}(t + \Delta t_{sj}) \leq \sum_s S_{sj}(t + \Delta t_{sj}) \\ R_{ij}(t + \Delta t_{ij}) \sum_s S_{sj}(t + \Delta t_{sj}), & \text{otherwise} \end{cases} \quad (10)$$

5. APPLICATION OF FLOW PROPAGATION MODEL TO SIMPLE CASE STUDY

5-1 Simulated condition for flow propagation model

The proposed flow propagation model is tested by two simple cases as shown in Figure 8. These cases are designed to test the crossings of bidirectional flow with an angle of 90 degrees and 45 degrees respectively. In each test, flow-density relationship as shown in Figure 9 is used and multi directional effect is not considered, i.e. $F(n_\alpha(t), \beta) = n_\alpha(t)$. The simulation time step, Δt , is set as 0.1 second. The direction of the flows is pre-determined and does not change during the simulation period since these tests are solely to illustrate the congestion phenomena as occurred in the modified CTM. The demand loaded to the study area is as shown in Figure 10. This figure shows the time-dependent demand loaded to each origin cell in every second.

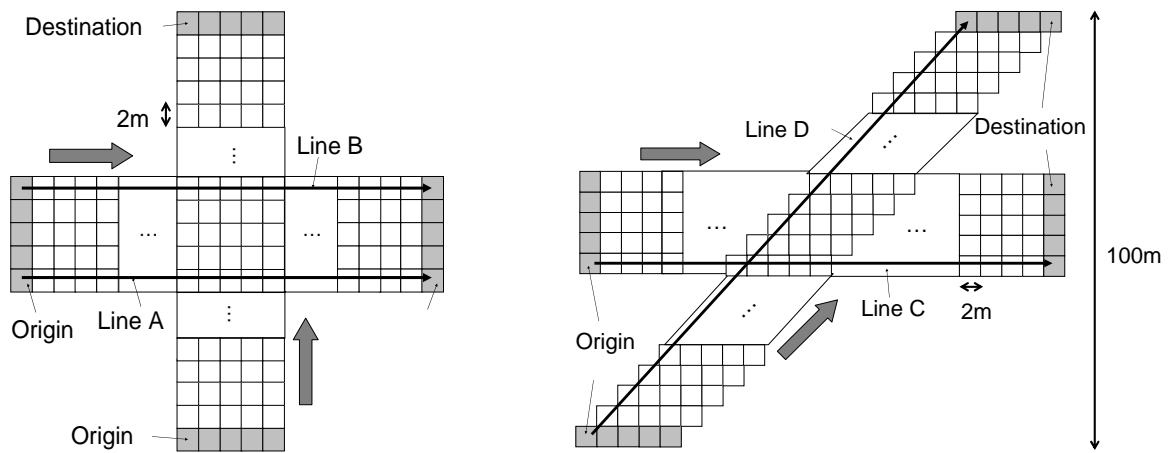

Figure 8: Simulated networks
(left hand side: Network 1 with 90 degree crossing,
right hand side: Network 2 with 45 degree diagonal crossing)

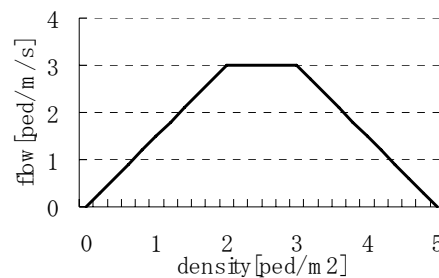

Figure 9: Flow-density curve used in the simulation tests

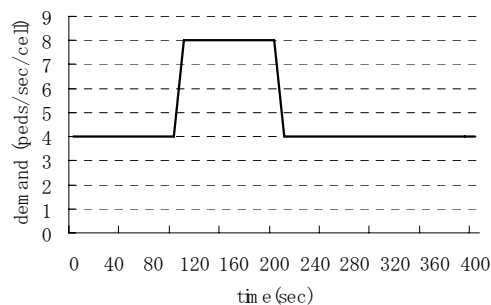

Figure 10: Demands loaded to the simulation tests

5-2 Simulation results

(i) The case with orthogonal crossing

Figure 11 shows evolution of pedestrian flows at different time steps. The value in each cell is the number of pedestrians in that cell at each time epoch. From this case, the congestion mainly concentrates on the south-west corner where the flows from different direction merge.. In the northern or eastern sides of the crossing area there is not a high density of flows as compared to the south-western area. This is because the flow entering the northern or eastern cells have already passed and been constrained by the capacities of the cells in the south-western side.

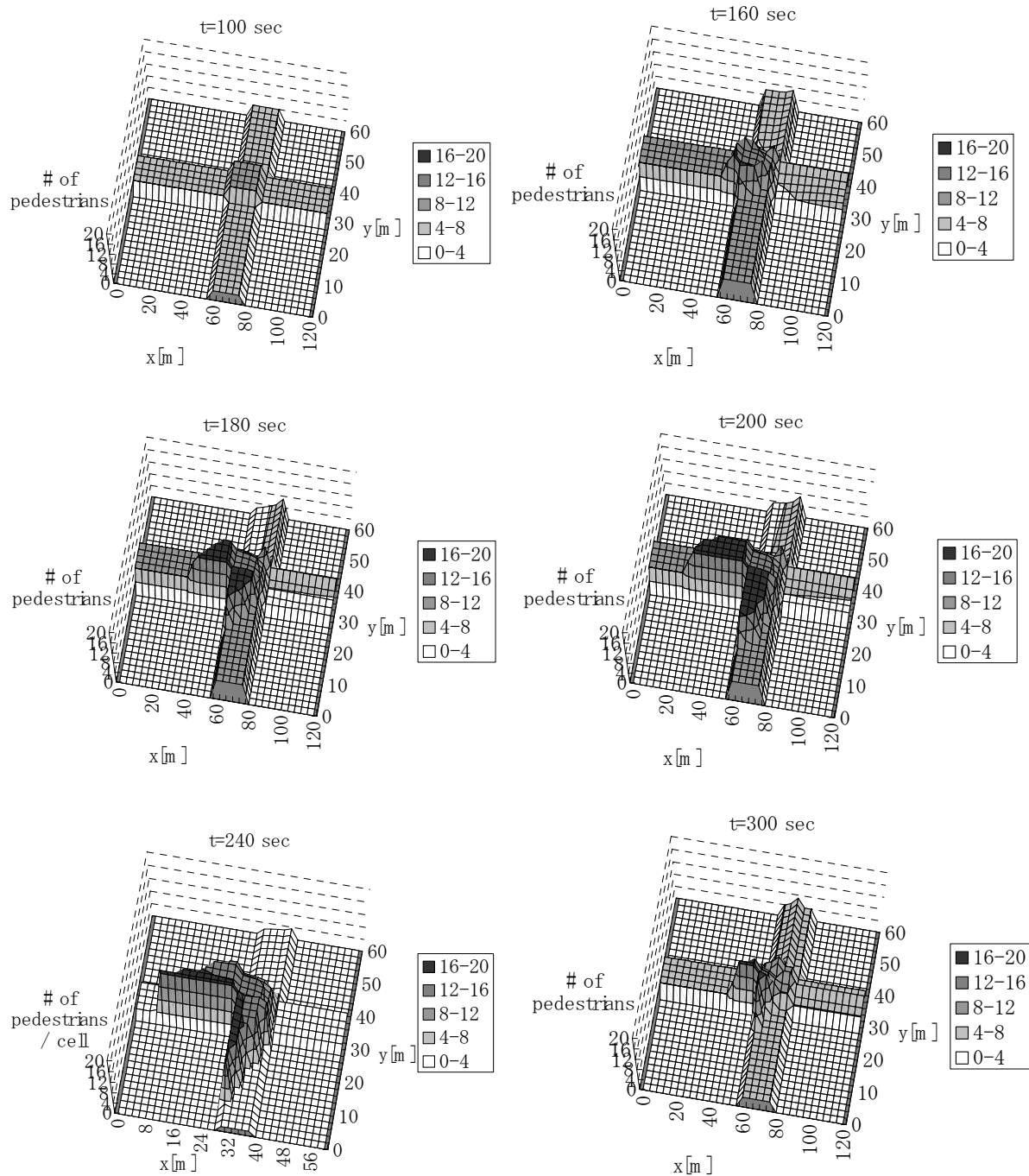

Figure 11: Flow distribution in each time

Two trajectories, Lines A and B, as shown in Figure 8 are investigated further. Figure 12 shows the time-space diagrams on Lines A and B. Shockwave phenomenon, which is similar to that of the vehicle flow, is observed in both cases of Lines A and B. The queue vanishing time on Line A is much longer than that of Line B. Since, the flows on Line A directly merged with the orthogonal flows, the merging effect is stronger than that of Line B. The amount of orthogonal flow was firstly constrained by the capacities of the cells on Line A, and thus the inflow of the orthogonal flow to cells on Line B became less and hence the pedestrian flows on Line B can pass through the crossing section more smoothly.

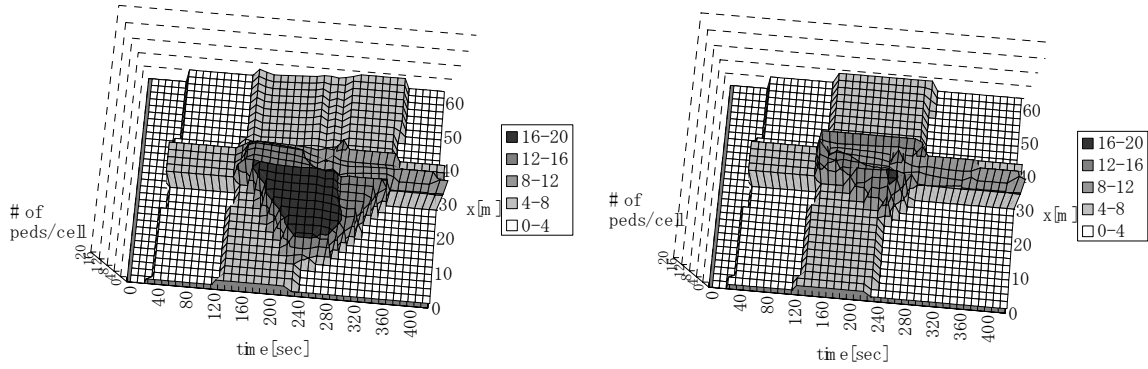

Figure 12: Time-space diagrams on Line A (left hand side) and on line B (right hand side) in case of orthogonal crossing

(ii) The case with diagonal crossing

The number of pedestrians on Line C and D (as shown in Figure 8) in the case of diagonal crossing is shown in Figure 13. Some similar types of shockwaves as occurred in the case with orthogonal crossings can also be observed. The difference between the cases with orthogonal and diagonal crossing is the travel time, since in the case with diagonal flow the moving distance in each direction is longer.

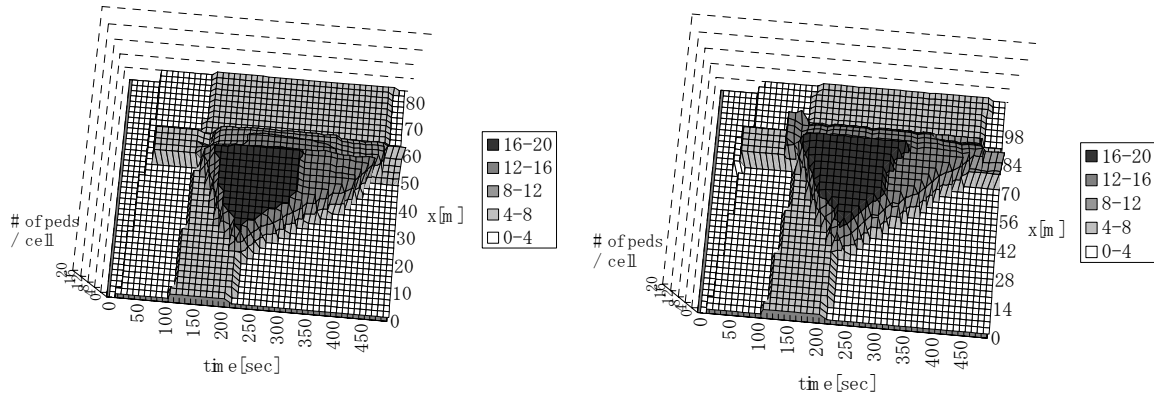

Figure 13: Time-space diagrams on Line C (left hand side) and on line D (right hand side) in case of 45 degree crossing

6. CONCLUSION

This paper proposed an integrated framework of a dynamic pedestrian model with route choice decision. The key attributes of this model include the representation of a collection of trajectories in an open space as a possible route in the area using the concept of cross section lines which is defined by adjacent obstacles. With this representation, the pedestrian choose his/her route at the tactical level in which a series of consecutive sub-areas are chosen as the main movement direction. Then, at the operational level the pedestrian will then traverse through the sub-area following the shortest path based upon the Dynamic User Optimum principle. On the physical side of the model, the cell-

transmission model (CTM) was extended to cope with the multi-directional flow case. In our future research, the whole modeling framework will be evaluated and compared against empirical behavioral data, particularly the density converting function and the flow propagation model.

ACKNOWLEDGEMENT

This research is funded by Japan Society for the Promotion of Science.

REFERENCES

1. DfT. *10-Year Transport Plan*. HMSO, 2000
2. Hoogendoorn, S. P. and Bovy, P. H. L. Pedestrian route-choice and activity scheduling theory and models. *Transportation Research Part B: Methodological*, Vol. 38, 2004, pp. 169
3. Kuwahara, M. and Akamatsu, T. Decomposition of the dynamic assignments with queues: DUO and DUE. *Transportation Research Part B*, Vol. 31, 1997, pp. 1-10
4. Antonini, G., Bierlaire, M. and Weber, M. Discrete choice models of pedestrian walking behavior. *Transportation Research Part B*, Vol. 40, 2006, pp. 667-687
5. Helbing, D. and Molnar, P. Social Force Model for Pedestrian Dynamics. *Physical Review*, Vol. 51, 1995, pp. 4282-4286
6. Blue, V. J. and Adler, J. L. Cellular automata microsimulation for modeling bi-directional pedestrian walkways. *Transportation Research Part B*, Vol. 35, 2001, pp. 293-312
7. Hughes, R. L. A continuum theory for the flow of pedestrians. *Transportation Research Part B*, Vol. 36, 2002, pp. 507-535
8. Lam, W. H. K., Lee, J. Y. S., Chan, K. S. and Goh, P. K. A generalised function for modeling bi-directional flow effects on indoor walkways in Hong Kong. *Transportation Research Part A*, Vol. 37, 2003, pp. 789-810
9. Daganzo, C. F. The cell transmission model, part II: Network traffic. *Transportation Research Part B*, Vol. 29, 1995, pp. 79-93
10. Daganzo, C. F. The Cell Transmission Model: A Simple Dynamic Representation of Highway Traffic Consistent with the Hydrodynamic Theory. *Transportation Research Part B*, Vol. 28, 1994, pp. 269-287
11. Gloor, C., Stucki, P. and Nagel, K. Hybrid techniques for pedestrian simulations. *in Proc. of 4th Swiss Transport Research Conference*, 2004
12. Algadhi, S. A. H. and Mahmassani, H. S. Modelling crowd behavior and movement: application to Makkah pilgrimage. *Transportation and Traffic Theory*, Vol. 1990, pp. 59-78
13. Naka, Y. *Study on complicated passenger flow in a railway station*. 1079. 1978 (in Japanese)